

Torque 0,57–6,8 N-m (5–60 IN.-LB.)

Hysteresis Tensioning Brakes
Hysteresis-Zugbremsen
Freni a Tensione Magnetica e Frizioni
Freins de Tension Hysteresis
Frenos de Tensión por Histéresis



Torque range	
Drehmomentbereich	0,57–6,8 N-m
Gamma di coppia	(5–60 IN.-LB.)
Intervalle de torsion	
Rango del par motor	

Heat dissipation	
Wärmeabfuhr	
Dissipazione massima del calore	145 Watt
Dissipation maximale de chaleur	
Disipación de calor máxima	

Max. RPM @ Min. Torque	1000 RPM
------------------------	----------

Max. RPM @ Max. Torque	200 RPM
------------------------	---------

Max. moment on shaft	
Biegemoment am schaft	
Momento di flessione dell'asse	113,0 N-m
Moment de flexion sur l'axe	(1000 IN.-LB.)
Momento de flexión del eje	

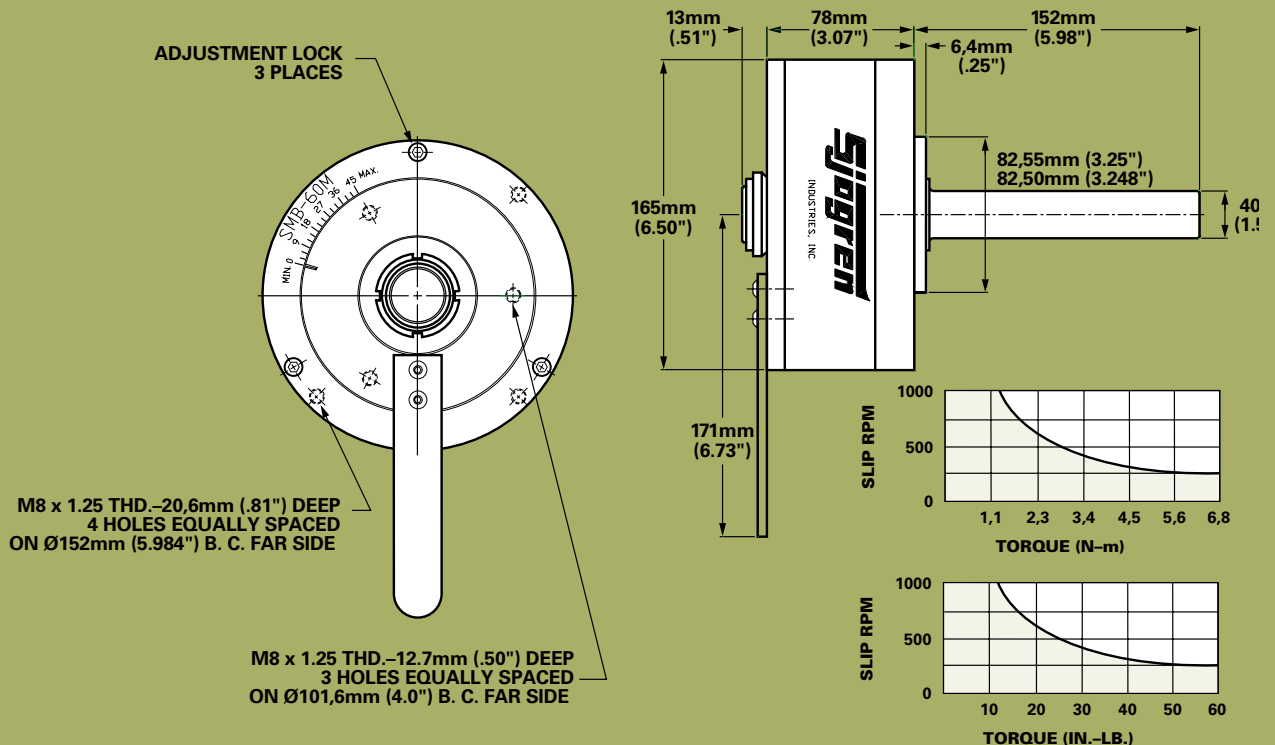

Shaded area under curve indicates safe heat dissipation operation of brake.