

# SMB-120M

## Torque 1,13–13,6 N-m (10–120 IN.-LB.)

Hysteresis Tensioning Brakes  
 Hysteresis-Zugbremsen  
 Freni a Tensione Magnetica e Frizioni  
 Freins de Tension Hysteresis  
 Frenos de Tensión por Histéresis

Torque range  
 Drehmomentbereich  
 Gamma di coppia  
 Intervalle de torsion  
 Rango del par motor

1,13–13,6 N-m  
 (10–120 IN.-LB.)

Heat dissipation  
 Wärmeabfuhr  
 Dissipazione massima del calore  
 Dissipation maximale de chaleur  
 Disipación de calor máxima

250 Watt

Max. RPM @ Min. Torque 1000 RPM

Max. RPM @ Max. Torque 200 RPM

Max. moment on shaft  
 Biegemoment am schaft  
 Momento di flessione dell'asse  
 Moment de flexion sur l'axe  
 Momento de flexión del eje

113,0 N-m  
 (1000 IN.-LB.)

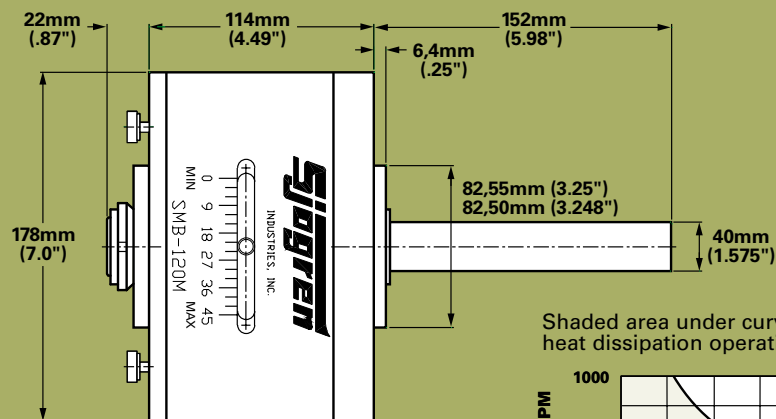

Shaded area under curve indicates safe heat dissipation operation of brake.

