

**Torque 0,11–1,36 N-m (1–12 IN.-LB.)**

Hysteresis Tensioning Brakes  
Hysteresis-Zugbremsen  
Freni a Tensione Magnetica e Frizioni  
Freins de Tension Hysteresis  
Frenos de Tensión por Histéresis



Torque range  
Drehmomentbereich 0,11–1,36 N-m  
Gamma di coppia (1–12 IN.-LB.)  
Intervalle de torsion  
Rango del par motor

Heat dissipation  
Wärmeabfuhr 25 Watt  
Dissipazione massima del calore  
Dissipation maximale de chaleur  
Disipación de calor máxima

Max. RPM @ Min. Torque 1000 RPM

Max. RPM @ Max. Torque 175 RPM

Max. moment on shaft  
Biegemoment am schaft 9,0 N-m  
Momento di flessione dell'asse (80 IN.-LB.)  
Moment de flexion sur l'axe  
Momento de flexión del eje

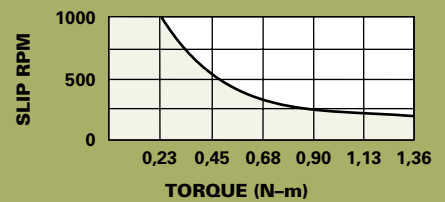
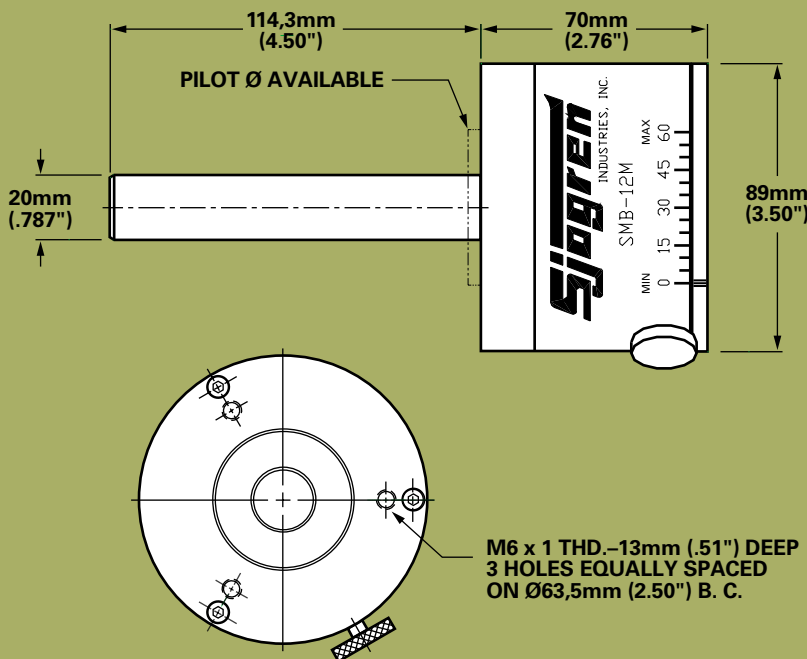

Shaded area under curve indicates safe heat dissipation operation of brake.

